

Forced Air

Forced Air Design Features

Standard Features:

- R410A
- Scroll Compressors
- Return Air Filter Rack with Filter
- Insulated Cabinet
- All Panels Removable for Easy Service
- Stainless Steel Frame with Galvanized Doors
- Stainless Steel Condensate Pan
- ECM Blower Motor
- High & Low Pressure Protection
- LED Diagnostics
- Built in Condensate Trap
- 10 Year Limited Warranty

Recommended Accessories:

- Buffer Tank
- Back-up heater
- Base pad
- Thermostat
- Flow Center
- Manifold
- Earth Loop Tubing
- Glycol

Optional:

- De-Superheater with Integral Circulating Pump
- Right or Left Hand Air Return
- Top, Side or Bottom Discharge
- Single Phase 220 volt or Three Phase 208, 230, 460 or 575 volt
- Built in Resistance Heat Strip 5, 10 or 15 kW
- Single Stage Compressor
- Dual Stage Compressor

NOTE:

Dimensions are the same for Up Flow and Down Flow

2 - 6 Ton Forced Air Neutral

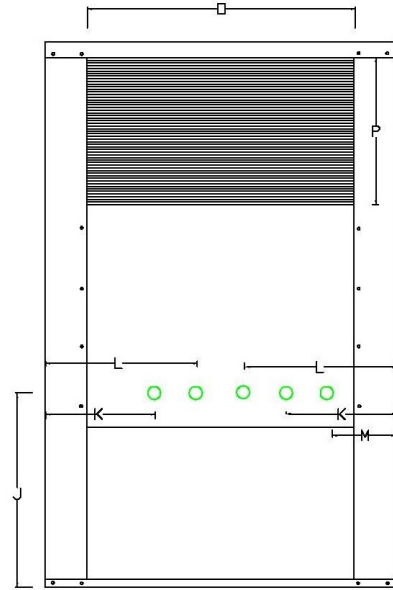
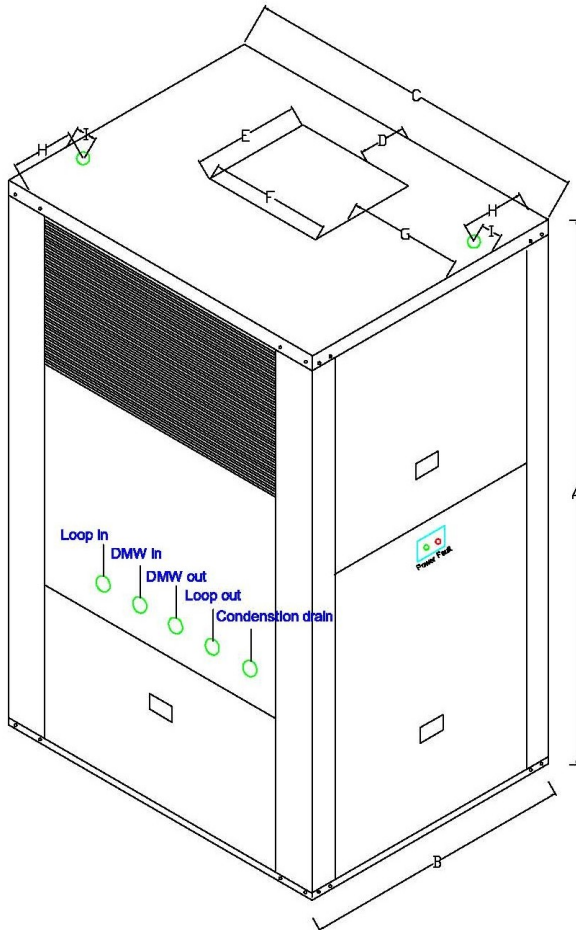

Loop 1" MPT
DMW and Condensation drain ½" MPT

Model	Dimension Data (in.)				Supply Air (in.)		Air Coil (in.)		Earth Loop (in.)		Weight Lbs.	Filter
	A	B	C	D	E	F	O	P	In	Out		
MA026	52	26	33 1/2	4 1/2	10 1/4	11 5/8	24	24	1	1	265	
MA038	60	26	33 1/2	4 1/2	10 1/4	11 5/8	25	30	1	1	275	
MA050	60	26	33 1/2	4 1/2	11 1/4	13	25	30	1	1	315	
MA062	66	28	33 1/2	4 1/2	11 1/4	13	25	36	1	1	325	
MA071	66	28	33 1/2	4 1/2	12 1/4	13 1/2	25	36	1	1	335	

2 - 6 Forced Air Neutral Down Draft

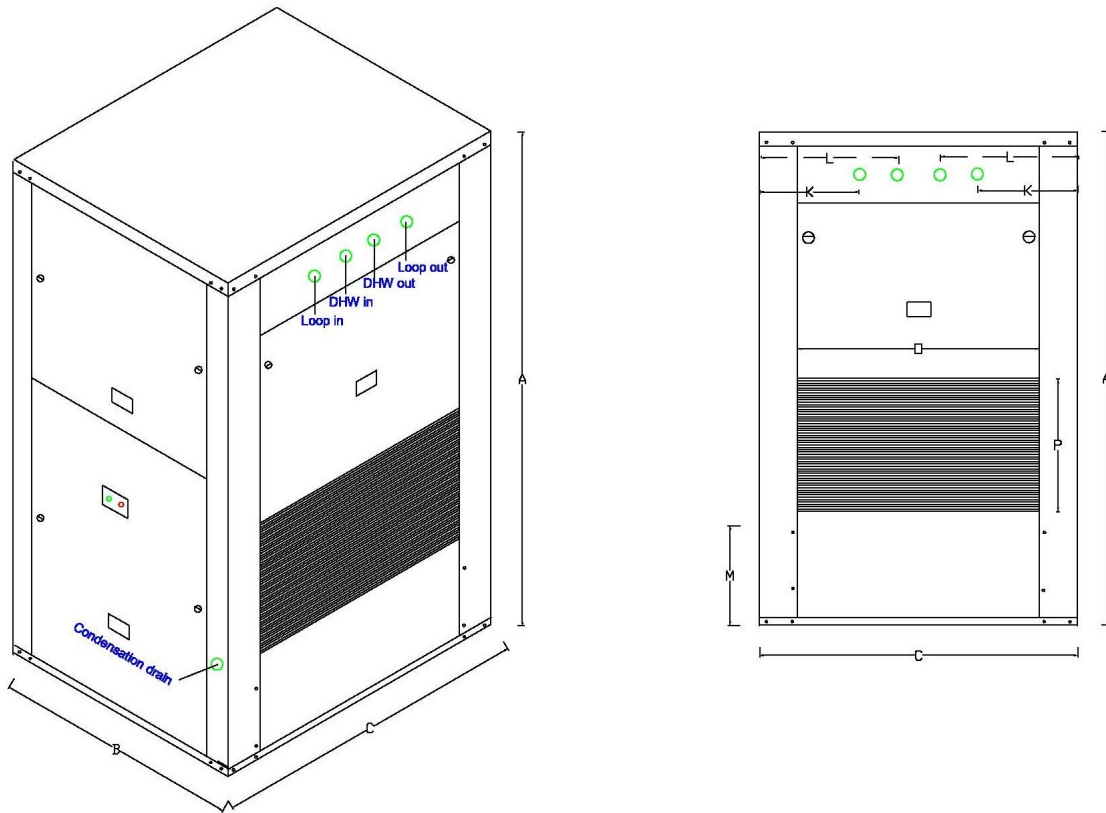

Model	Dimension Data (in.)				Supply Air (in.)		Air Coil (in.)		Earth Loop (in.)		Weight Lbs.	Filter
	A	B	C	D	E	F	O	P	In	Out		
MA026	52	26	33 1/2	4 1/2	10 1/4	11 5/8	24	24	1	1	265	
MA038	60	26	33 1/2	4 1/2	10 1/4	11 5/8	25	30	1	1	275	
MA050	60	26	33 1/2	4 1/2	11	13	25	30	1	1	315	
MA062	66	28	33 1/2	4 1/2	11	13	25	36	1	1	325	
MA071	66	28	33 1/2	4 1/2	12 1/4	13 1/2	25	36	1	1	335	

Forced Air Horizontal

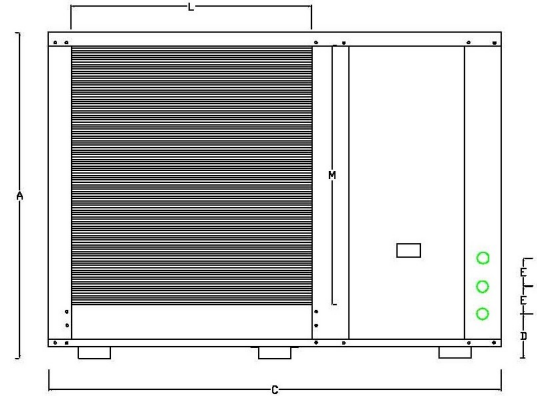
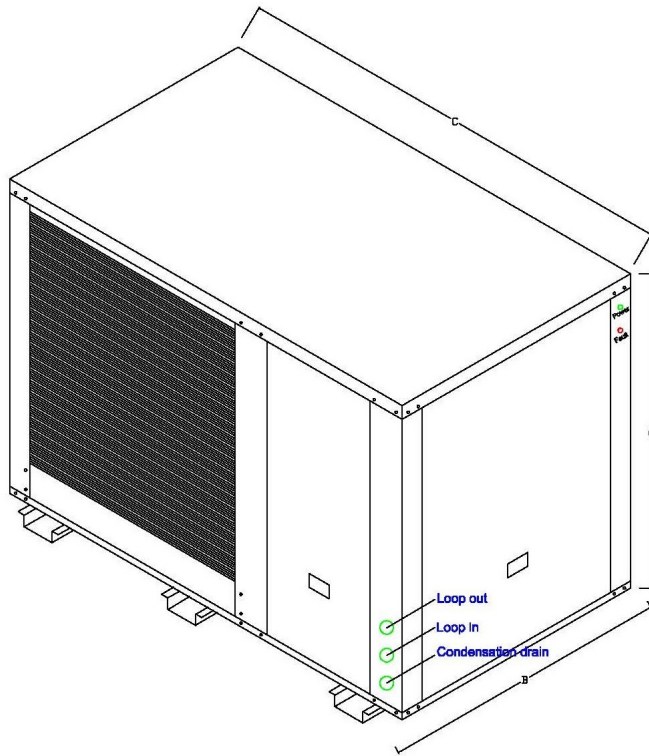

Loop in and out 1" MPT
 Condensation drain 1/2" MPT

Model	Dimension Data (in.)					Supply Air (in.)		Air Coil (in.)		Earth Loop (in.)		Weight Lbs.	Filter
	A	B	C	D	E			L	M	In	Out		
MA026	32	28 1/2	49	4 3/4	3	10 1/4	11 5/8	24	24	1	1	315	
MA038	38	28 1/2	49	4 3/4	3	10 1/4	11 5/8	25	30	1	1	325	
MA050	38	28 1/2	49	4 3/4	3	11 1/4	13	25	30	1	1	355	
MA062	44	28 1/2	49	4 3/4	3	11 1/4	13	25	36	1	1	365	
MA071	44	28 1/2	49	4 3/4	3	12 1/4	13 1/2	25	36	1	1	375	

Engineering Manual

Forced Air

Single Stage Water to Air Submittal/Performance Data

Project: _____ Date: _____
Engineer: _____ Unit No. _____
Contractor: _____ PO. _____



GeoFurnace Manufacturing

**Magnum
Water Source Heat Pump**

**(MA-S) Single Stage
Water to Air
Submittal Data**

**Models MA 026-071S
60 Hz - R410A**

2-6 Ton - Single Stage Forced Air Performance Summary

Project: _____ Date: _____
 Engineer: _____ Unit No. _____
 Contractor: _____ PO: _____



Single Stage Forced Air - R410A Performance ISO 13256-1

Magnum Series Water Source Heat Pump

Model	Water Loop				Ground Water				Ground Loop			
	Heating 68OF EWT		Cooling 86OF EWT		Heating 50OF EWT		Cooling 59OF EWT		Heating 32/41OF EWT Full/Par		Cooling 77/68OF EWT Full/Par	
	kBtu/hr	COP	kBtu/hr	EER	kBtu/hr	COP	kBtu/hr	EER	kBtu/hr	COP	kBtu/hr	EER
26	31.9	4.7	25.8	15.1	26.2	4.2	28.4	20.9	19.0	3.4	26.9	17.0
38	45.5	4.9	37.4	16.4	37.1	4.3	40.7	23.5	30.3	3.8	38.8	18.7
50	57.7	5.0	47.4	16.7	46.3	4.3	51.6	23.7	37.0	3.7	49.2	19.0
62	75.8	5.0	62.5	16.7	61.8	4.3	68.1	24.2	50.4	3.9	64.9	19.2
71	83.0	5.1	68.6	17.0	67.7	4.4	74.8	24.2	54.1	3.8	71.3	19.3

Heating capacity is based on entering air temperature of 68 dry bulb / 59 wet bulb
 Cooling capacity based on entering air temperature of 80.6 dry bulb / 66.2 wet bulb
 Operation below 40°F EWT is based upon a 15% antifreeze solution.
 All performance is based upon the lower voltage of dual voltage rated units.

2/9/2010

Electrical Specifications

Model	Voltage	Elect. Symbol	Compressor		Source Pump	Fan Motor FLA	HWG Pump FLA	Total Unit FLA	Min. Ampacity*	Max. Fuse/ Breaker*
			RLA	LRA						
26	208/230-1-60	1	10.0	53.0	1.5	4.3	0.4	16.2	18.7	25.0
	200/230-3-60	2	#N/A	#N/A	1.5	4.3	0.4	#N/A	#N/A	#N/A
	460-3-60	3	#N/A	#N/A	1.5	4.3	0.4	#N/A	#N/A	#N/A
38	208/230-1-60	1	17.0	96.7	1.5	4.3	0.4	23.2	27.5	40.0
	200/230-3-60	2	12.8	95.0	1.5	4.3	0.4	19.0	22.2	35.0
	460-3-60	3	6.4	45.0	1.5	4.3	0.4	12.6	14.2	20.0
50	208/230-1-60	1	21.0	115.0	3.0	4.3	0.4	28.7	34.0	50.0
	200/230-3-60	2	16.0	115.0	3.0	4.3	0.4	23.7	27.7	40.0
	460-3-60	3	7.7	50.0	3.0	4.3	0.4	15.4	17.3	25.0
62	208/230-1-60	1	26.3	150.0	3.0	6.8	0.4	36.5	43.1	65.0
	200/230-3-60	2	17.6	120.0	3.0	6.8	0.4	27.8	32.2	45.0
	460-3-60	3	8.3	70.0	3.0	6.8	0.4	18.5	20.6	25.0
71	208/230-1-60	1	30.1	145.0	3.0	9.1	0.4	42.6	50.1	80.0
	200/230-3-60	2	17.6	120.0	3.0	9.1	0.4	30.1	34.5	50.0
	460-3-60	3	9.6	70.0	3.0	9.1	0.4	22.1	24.5	30.0

*Where calculations are based on:

MCA = 1.25 x RLA compressor + FLA other motors

MOP = 2.25 x RLA largest compressor + 1.00 x FLA other motors

Ensure that all loads on the supply line are added into the equations above if some of the cells in the above table are blank

HACR circuit breaker for use in USA only. All fuses Class RK-5

For #N/A, the specified voltage is NOT available

4/1/2010

Pressure Drop Specifications

Model	GPM	Pressure Drop (psi)*						
		Entering Water Temperature °F						
		20	30	50	70	90	110	120
26	3.6	3.1	3.0	2.1	2.0	1.9	1.7	1.7
	5.3	4.5	4.3	3.1	2.9	2.7	2.5	2.4
	7.1	6.3	6.1	4.4	4.1	3.8	3.5	3.4
38	4.5	1.9	1.9	1.3	1.3	1.2	1.1	1.0
	6.8	2.4	2.3	1.7	1.6	1.4	1.3	1.3
	9.0	3.2	3.1	2.2	2.1	2.0	1.8	1.8
50	6.2	2.1	2.1	1.5	1.4	1.3	1.2	1.1
	9.3	4.1	4.0	2.8	2.7	2.5	2.3	2.2
	12.4	6.5	6.3	4.5	4.2	3.9	3.6	3.5
62	7.7	1.9	1.8	1.3	1.2	1.2	1.1	1.0
	11.5	3.5	3.4	2.4	2.3	2.1	2.0	1.9
	15.4	5.6	5.5	3.9	3.7	3.4	3.2	3.0
71	9.0	1.8	1.7	1.2	1.2	1.1	1.0	1.0
	13.5	3.5	3.4	2.4	2.3	2.1	2.0	1.9
	18.0	5.7	5.5	3.9	3.7	3.5	3.2	3.1

*Pressure drop thru each coaxial heat exchanger - below 40°F based on 23% PG

4/1/2010

GeoFurnace works continually to improve its products. As a result, the design and specifications of each product at the time of order may be changed without notice. Please contact GeoFurnace at 1-605-854-9205 for latest design and specifications. Purchaser's approval of this data set signifies that the equipment is acceptable under the provisions of the job specification. Statements and other information contained herein are not express warranties and do not form the basis of any contract between the parties, but are merely GeoFurnace's opinion or commendation of its products.

2 Ton - Single Stage Forced Air Submittal/Performance Data

Project: _____ Date: _____
 Engineer: _____ Unit No. _____
 Contractor: _____ PO: _____



MA026S Series - R410A

Rated Airflow: 900 Heating / 900 Cooling

Magnum Series Water Source Heat Pump

EWT °F	WATER/BRINE			Heating - EAT 70°F					Cooling - EAT 80/67°F				
	FLOW gpm	PD psi	PD ft.	HC kBtu/hr	Pwr kW	HE kBtu/hr	LAT °F	COP	TC kBtu/hr	SC kBtu/hr	Pwr kW	HR kBtu/hr	EER
20	3.6	2.7	6.3	12.9	1.6	7.4	83.3	2.4	Operation Not Recommended				
	5.3	3.9	9.1										
	7.1	5.5	12.8										
30	3.6	2.9	6.7	16.5	1.7	10.8	86.9	2.9	30.0	20.9	1.1	33.9	26.6
	5.3	3.8	8.8	17.7	1.7	11.9	88.2	3.1	30.8	21.3	1.0	34.3	29.8
	7.1	5.4	12.4										
40	3.6	2.2	5.1	20.8	1.7	14.9	91.4	3.5	28.8	20.7	1.4	33.4	21.1
	5.3	3.2	7.4	22.5	1.7	16.5	93.1	3.8	29.8	21.2	1.2	34.0	23.9
	7.1	4.5	10.4	23.2	1.8	17.2	93.9	3.8	30.3	21.6	1.2	34.3	26.0
50	3.6	2.1	5.0	24.3	1.8	18.1	95.0	3.9	28.3	20.8	1.5	33.4	19.1
	5.3	3.1	7.1	25.3	1.8	19.1	96.1	4.0	29.3	21.3	1.4	34.0	21.5
	7.1	4.4	10.1	26.1	1.9	19.7	96.9	4.1	29.7	21.8	1.3	34.2	22.9
60	3.6	2.1	4.8	26.9	1.9	20.4	97.7	4.2	27.7	20.8	1.6	33.2	17.1
	5.3	3.0	6.9	28.3	1.9	21.8	99.2	4.3	28.7	21.3	1.5	33.7	19.3
	7.1	4.2	9.8	29.2	2.0	22.5	100.0	4.4	29.0	21.7	1.4	33.9	20.2
70	3.6	2.0	4.6	29.7	2.0	22.9	100.5	4.4	26.8	20.5	1.8	32.8	15.3
	5.3	2.9	6.7	31.5	2.0	24.6	102.4	4.6	27.8	21.0	1.6	33.4	17.1
	7.1	4.1	9.5	32.3	2.0	25.3	103.3	4.6	28.1	21.5	1.6	33.4	17.8
80	3.6	1.9	4.5	32.4	2.1	25.3	103.3	4.6	25.8	20.2	1.9	32.3	13.5
	5.3	2.8	6.5	34.6	2.1	27.4	105.6	4.8	26.8	20.6	1.8	32.8	15.2
	7.1	4.0	9.1	35.5	2.1	28.2	106.5	4.9	27.0	21.1	1.7	32.8	15.7
90	3.6	1.9	4.3	35.1	2.2	27.7	106.1	4.7	24.5	19.6	2.1	31.6	11.8
	5.3	2.7	6.2	37.7	2.2	30.2	108.8	5.1	25.6	20.1	1.9	32.1	13.3
	7.1	3.8	8.8	38.6	2.2	31.1	109.7	5.1	25.7	20.6	1.9	32.1	13.7
100	3.6	1.8	4.2	Operation Not Recommended					23.0	18.8	2.3	30.7	10.2
	5.3	2.6	6.0						24.1	19.3	2.1	31.3	11.5
	7.1	3.7	8.5						24.3	19.8	2.0	31.3	11.9
110	3.6	1.7	4.0	Operation Not Recommended					21.4	17.9	2.4	29.7	8.7
	5.3	2.5	5.8						22.5	18.4	2.3	30.3	9.9
	7.1	3.5	8.2						22.7	18.9	2.2	30.3	10.3

Interpolation is permissible; extrapolation is not.

Operation below 40°F EWT is based upon a 15% antifreeze solution.

All performance is based upon the lower voltage of dual voltage rated units.

Table does not reflect fan or pump power corrections for ARI/ISO conditions.

See performance correction tables for operating conditions other than those listed above.

Performance ISO 13256-1

Loading Capacity	Water Loop				Ground Water				Ground Loop			
	Heating 68°F EWT		Cooling 86°F EWT		Heating 50°F EWT		Cooling 59°F EWT		Heating 2/41°F EWT Full/Part		Cooling 7/68°F EWT Full/Part	
	kBtu/hr	COP	kBtu/hr	EER	kBtu/hr	COP	kBtu/hr	EER	kBtu/hr	COP	kBtu/hr	EER
Full	31.9	4.7	25.8	15.1	26.2	4.2	28.4	20.9	19.0	3.4	26.9	17.0

Electrical Specification

Voltage	Elect. Symbol	Compressor		Source Pump	Fan Motor FLA	HWG Pump FLA	Total Unit FLA	Min. Ampacity *	Max. Fuse/ Breaker*
		RLA	LRA						
208/230-1-60	1	10	53	1.5	4.3	0.4	16.2	18.7	25
200/230-3-60	2	#N/A	#N/A	1.5	4.3	0.4	#N/A	#N/A	#N/A
460-3-60	3	#N/A	#N/A	1.5	4.3	0.4	#N/A	#N/A	#N/A

*Where calculations are based on:

MCA = 1.25 x RLA compressor + Fan FLA + Pump FLA

MOP = 2.25 x RLA largest compressor + 1.00 x FLA other motors

Ensure that all loads on the supply line are added into the equations above if some of the cells in the above table are blank

GeoFurnace works continually to improve its products. As a result, the design and specifications of each product at the time of order may be changed without notice. Please contact GeoFurnace at 1-605-854-9205 for latest design and specifications. Purchaser's approval of this data set signifies that the equipment is acceptable under the provisions of the job specification. Statements and other information contained herein are not express warranties and do not form the basis of any contract between the parties, but are merely GeoFurnace's opinion or commendation of its products.

3 Ton - Single Stage Forced Air Submittal/Performance Data

Project: _____ Date: _____
 Engineer: _____ Unit No. _____
 Contractor: _____ PO. _____



MA038S Series - R410A

Rated Airflow: 1270 Heating / 1200 Cooling

Magnum Series Water Source Heat Pump

EWT °F	WATER/BRINE			Heating - EAT 70°F					Cooling - EAT 80/67°F				
	FLOW gpm	PD psi	PD ft.	HC kBtu/hr	Pwr kW	HE kBtu/hr	LAT °F	COP	TC kBtu/hr	SC kBtu/hr	Pwr kW	HR kBtu/hr	EER
20	4.5	1.7	3.9	25.0	2.3	17.1	88.3	3.1	Operation Not Recommended				
	6.8	2.1	4.9										
	9.0	2.8	6.6										
30	4.5	1.8	4.2	27.8	2.4	19.7	90.3	3.4	42.3	27.8	1.4	47.1	30.2
	6.8	2.0	4.7	28.8	2.4	20.6	91.0	3.5	43.2	28.5	1.3	47.6	33.7
	9.0	2.8	6.4										
40	4.5	1.4	3.2	30.7	2.4	22.3	92.4	3.7	41.0	27.6	1.7	46.9	23.8
	6.8	1.7	3.9	31.7	2.5	23.3	93.1	3.8	42.2	28.2	1.6	47.5	27.2
	9.0	2.3	5.3	32.8	2.5	24.2	93.9	3.8	42.8	28.9	1.4	47.8	29.6
50	4.5	1.3	3.1	34.3	2.5	25.7	95.0	4.0	40.6	27.7	1.9	47.1	21.4
	6.8	1.7	3.8	35.8	2.6	27.1	96.1	4.1	41.8	28.4	1.7	47.7	24.3
	9.0	2.2	5.2	37.0	2.6	28.1	97.0	4.2	42.3	29.0	1.6	47.8	26.0
60	4.5	1.3	3.0	38.1	2.6	29.2	97.8	4.2	39.9	27.7	2.1	47.0	19.0
	6.8	1.6	3.7	40.2	2.7	31.1	99.3	4.4	41.1	28.3	1.9	47.6	21.6
	9.0	2.2	5.0	41.4	2.7	32.3	100.2	4.5	41.5	29.0	1.8	47.7	22.8
70	4.5	1.3	2.9	42.2	2.7	32.8	100.7	4.5	38.8	27.4	2.3	46.7	16.7
	6.8	1.6	3.6	44.9	2.8	35.5	102.7	4.8	40.1	28.0	2.1	47.3	19.0
	9.0	2.1	4.9	46.2	2.8	36.7	103.7	4.9	40.4	28.7	2.0	47.3	19.9
80	4.5	1.2	2.8	46.4	2.8	36.7	103.8	4.8	37.3	26.9	2.6	46.0	14.5
	6.8	1.5	3.5	49.9	2.9	40.1	106.4	5.1	38.7	27.5	2.3	46.7	16.6
	9.0	2.0	4.7	51.4	2.9	41.5	107.5	5.2	39.0	28.2	2.3	46.7	17.2
90	4.5	1.2	2.7	50.8	3.0	40.7	107.0	5.0	35.4	26.1	2.8	45.1	12.5
	6.8	1.4	3.3	55.3	3.0	45.1	110.3	5.4	37.0	26.8	2.6	45.8	14.3
	9.0	2.0	4.5	56.9	3.0	46.6	111.5	5.5	37.2	27.4	2.5	45.8	14.8
100	4.5	1.1	2.6	Operation Not Recommended					33.1	25.1	3.1	43.8	10.5
	6.8	1.4	3.2						34.8	25.8	2.9	44.6	12.2
	9.0	1.9	4.4						35.1	26.4	2.8	44.6	12.6
110	4.5	1.1	2.5	Operation Not Recommended					30.3	23.9	3.5	42.1	8.7
	6.8	1.3	3.1						32.2	24.6	3.2	43.1	10.1
	9.0	1.8	4.2						32.6	25.2	3.1	43.2	10.6

Interpolation is permissible; extrapolation is not.
 Operation below 40°F EWT is based upon a 15% antifreeze solution.
 All performance is based upon the lower voltage of dual voltage rated units.
 Table does not reflect fan or pump power corrections for ARI/ISO conditions.
 See performance correction tables for operating conditions other than those listed above.

Performance ISO 13256-1

Loading/ Capacity	Water Loop				Ground Water				Ground Loop			
	Heating 68°F EWT		Cooling 86°F EWT		Heating 50°F EWT		Cooling 59°F EWT		Heating 32/41°F EWT Full/Part		Cooling 77/68°F EWT Full/Part	
	kBtu/hr	COP	kBtu/hr	EER	kBtu/hr	COP	kBtu/hr	EER	kBtu/hr	COP	kBtu/hr	EER
Full	45.5	4.9	37.4	16.4	37.1	4.3	40.7	23.5	30.3	3.8	38.8	18.7

Electrical Specification

Voltage	Elect. Symbol	Compressor		Source Pump	Fan Motor FLA	HWG Pump FLA	Total Unit FLA	Min. Ampacity*	Max. Fuse/ Breaker*
		RLA	LRA						
208/230-1-60	1	17	96.7	1.5	4.3	0.4	23.2	27.5	40
200/230-3-60	2	12.8	95	1.5	4.3	0.4	19.0	22.2	35
460-3-60	3	6.4	45	1.5	4.3	0.4	12.6	14.2	20

*Where calculations are based on:

$$MCA = 1.25 \times \text{RLA compressor} + \text{Fan FLA} + \text{Pump FLA}$$

$$MOP = 2.25 \times \text{RLA largest compressor} + 1.00 \times \text{FLA other motors}$$

Ensure that all loads on the supply line are added into the equations above if some of the cells in the above table are blank

GeoFurnace works continually to improve its products. As a result, the design and specifications of each product at the time of order may be changed without notice. Please contact GeoFurnace at 1-605-854-9205 for latest design and specifications. Purchaser's approval of this data set signifies that the equipment is acceptable under the provisions of the job specification. Statements and other information contained herein are not express warranties and do not form the basis of any contract between the parties, but are merely GeoFurnace's opinion or commendation of its products.

4 Ton - Single Stage Forced Air Submittal/Performance Data

Project: _____ Date: _____
 Engineer: _____ Unit No. _____
 Contractor: _____ PO: _____



MA050S Series - R410A

Rated Airflow: 1600 Heating / 1580 Cooling

Magnum Series Water Source Heat Pump

EWT °F	WATER/BRINE			Heating - EAT 70°F					Cooling - EAT 80/67°F				
	FLOW gpm	PD psi	PD ft.	HC kBtu/hr	Pwr kW	HE kBtu/hr	LAT °F	COP	TC kBtu/hr	SC kBtu/hr	Pwr kW	HR kBtu/hr	EER
20	6.2	1.9	4.3	30.3	2.9	20.3	87.6	3.0	Operation Not Recommended				
	9.3	3.6	8.3										
	12.4	5.7	13.1										
30	6.2	2.0	4.5	31.9	3.0	21.6	88.5	3.1	53.5	36.6	1.8	59.8	29.2
	9.3	3.5	8.1						54.5	37.5	1.7	60.4	31.7
	12.4	5.5	12.8						55.5	38.5	1.6	61.0	33.4
40	6.2	1.5	3.5	37.7	3.1	27.2	91.8	3.6	52.0	36.3	2.2	59.4	23.8
	9.3	2.9	6.8						53.5	37.2	2.0	60.3	26.8
	12.4	4.6	10.7						54.2	38.0	1.9	60.7	28.7
50	6.2	1.5	3.4	42.6	3.2	31.7	94.7	3.9	51.5	36.5	2.4	59.6	21.5
	9.3	2.8	6.6						53.0	37.4	2.2	60.5	24.3
	12.4	4.5	10.4						53.6	38.2	2.1	60.7	25.8
60	6.2	1.4	3.3	47.8	3.3	36.5	97.7	4.2	50.6	36.5	2.6	59.5	19.2
	9.3	2.8	6.4						52.2	37.3	2.4	60.3	21.8
	12.4	4.3	10.0						52.6	38.2	2.3	60.4	22.9
70	6.2	1.4	3.2	53.3	3.4	41.6	100.8	4.5	49.2	36.1	2.9	59.1	17.0
	9.3	2.7	6.2						50.9	36.9	2.6	59.9	19.3
	12.4	4.2	9.7						51.2	37.8	2.5	59.9	20.1
80	6.2	1.3	3.1	59.0	3.6	46.8	104.1	4.8	47.4	35.4	3.2	58.3	14.8
	9.3	2.6	6.0						49.1	36.2	2.9	59.1	16.8
	12.4	4.1	9.4						49.4	37.1	2.8	59.1	17.5
90	6.2	1.3	3.0	64.8	3.7	52.1	107.5	5.1	45.1	34.4	3.6	57.3	12.7
	9.3	2.5	5.8						47.0	35.2	3.2	58.0	14.5
	12.4	3.9	9.1						47.2	36.1	3.1	58.0	15.0
100	6.2	1.2	2.9	70.6	3.8	57.9	111.9	5.7	42.4	33.1	4.0	55.9	10.7
	9.3	2.4	5.6						44.4	33.9	3.6	56.7	12.3
	12.4	3.8	8.7						44.7	34.8	3.5	56.6	12.8
110	6.2	1.2	2.7	76.4	3.9	63.7	116.1	6.3	39.2	31.5	4.4	54.3	8.9
	9.3	2.3	5.3						41.4	32.3	4.0	55.1	10.3
	12.4	3.6	8.4						41.7	33.2	3.9	55.0	10.7

Interpolation is permissible; extrapolation is not.
 Operation below 40°F EWT is based upon a 15% antifreeze solution.
 All performance is based upon the lower voltage of dual voltage rated units.
 Table does not reflect fan or pump power corrections for ARI/ISO conditions.
 See performance correction tables for operating conditions other than those listed above.

Performance ISO 13256-1

Loading/ Capacity	Water Loop				Ground Water				Ground Loop			
	Heating 68°F EWT		Cooling 86°F EWT		Heating 50°F EWT		Cooling 59°F EWT		Heating 32/41°F EWT Full/Part		Cooling 77/68°F EWT Full/Part	
	kBtu/hr	COP	kBtu/hr	EER	kBtu/hr	COP	kBtu/hr	EER	kBtu/hr	COP	kBtu/hr	EER
Full	57.7	5.0	47.4	16.7	46.3	4.3	51.6	23.7	37.0	3.7	49.2	19.0

Electrical Specification

Voltage	Elect. Symbol	Compressor		Source Pump	Fan Motor FLA	HWG Pump FLA	Total Unit FLA	Min. Ampacity*	Max. Fuse/ Breaker*
		RLA	LRA						
208/230-1-60	1	21	115	3.0	4.3	0.4	28.7	34.0	50
200/230-3-60	2	16	115	3.0	4.3	0.4	23.7	27.7	40
460-3-60	3	7.7	50	3.0	4.3	0.4	15.4	17.3	25

*Where calculations are based on:

$$MCA = 1.25 \times \text{RLA compressor} + \text{Fan FLA} + \text{Pump FLA}$$

$$MOP = 2.25 \times \text{RLA largest compressor} + 1.00 \times \text{FLA other motors}$$

Ensure that all loads on the supply line are added into the equations above if some of the cells in the above table are blank

GeoFurnace works continually to improve its products. As a result, the design and specifications of each product at the time of order may be changed without notice. Please contact GeoFurnace at 1-605-854-9205 for latest design and specifications. Purchaser's approval of this data set signifies that the equipment is acceptable under the provisions of the job specification. Statements and other information contained herein are not express warranties and do not form the basis of any contract between the parties, but are merely GeoFurnace's opinion or commendation of its products.

5 Ton - Single Stage Forced Air Submittal/Performance Data

Project: _____ Date: _____
 Engineer: _____ Unit No. _____
 Contractor: _____ PO: _____



MA062S Series - R410A

Magnum Series

Rated Airflow: 2000 Heating / 1800 Cooling

Water Source Heat Pump

EWT °F	WATER/BRINE			Heating - EAT 70°F					Cooling - EAT 80/67°F				
	FLOW gpm	PD psi	PD ft.	HC kBtu/hr	Pwr kW	HE kBtu/hr	LAT °F	COP	TC kBtu/hr	SC kBtu/hr	Pwr kW	HR kBtu/hr	EER
20	7.7	1.7	3.9	38.4	3.8	25.4	87.8	2.9	Operation Not Recommended				
	11.5	3.1	7.0										
	15.4	4.9	11.4										
30	7.7	1.8	4.1	45.3	3.9	32.0	91.0	3.4	71.0	41.7	2.3	78.8	31.3
	11.5	3.0	6.8	48.0	4.0	34.4	92.2	3.5	72.5	42.7	2.1	79.6	34.9
	15.4	4.8	11.1										
40	7.7	1.4	3.1	51.1	4.0	37.4	93.7	3.7	68.8	41.4	2.8	78.3	24.6
	11.5	2.5	5.7	52.8	4.1	39.0	94.5	3.8	70.8	42.3	2.5	79.4	28.1
	15.4	4.0	9.3	54.6	4.1	40.5	95.3	3.9	71.9	43.3	2.3	79.8	30.7
50	7.7	1.3	3.0	57.2	4.2	43.0	96.5	4.0	68.1	41.6	3.1	78.6	22.0
	11.5	2.4	5.6	59.7	4.2	45.3	97.6	4.1	70.1	42.6	2.8	79.6	25.1
	15.4	3.9	9.0	61.6	4.3	47.0	98.5	4.2	70.9	43.6	2.6	79.9	26.9
60	7.7	1.3	2.9	63.6	4.3	48.8	99.4	4.3	66.8	41.5	3.4	78.5	19.5
	11.5	2.3	5.4	67.0	4.4	52.1	101.0	4.5	68.9	42.5	3.1	79.5	22.2
	15.4	3.8	8.7	69.1	4.4	54.0	102.0	4.6	69.5	43.5	3.0	79.6	23.5
70	7.7	1.2	2.8	70.3	4.5	54.9	102.5	4.6	64.9	41.1	3.8	77.9	17.1
	11.5	2.3	5.2	74.9	4.5	59.4	104.7	4.8	67.2	42.1	3.4	78.9	19.5
	15.4	3.7	8.4	77.1	4.6	61.4	105.7	4.9	67.6	43.0	3.3	78.9	20.4
80	7.7	1.2	2.8	77.3	4.7	61.3	105.8	4.8	62.4	40.3	4.2	76.8	14.8
	11.5	2.2	5.0	83.2	4.7	67.1	108.5	5.2	64.8	41.3	3.8	77.9	16.9
	15.4	3.5	8.2	85.7	4.8	69.4	109.7	5.3	65.2	42.3	3.7	77.9	17.6
90	7.7	1.2	2.7	84.7	4.9	68.0	109.2	5.1	59.2	39.2	4.7	75.1	12.6
	11.5	2.1	4.9	92.2	4.9	75.3	112.7	5.5	61.9	40.1	4.3	76.4	14.5
	15.4	3.4	7.9	94.9	5.0	77.8	113.9	5.6	62.3	41.1	4.1	76.3	15.1
100	7.7	1.1	2.6	Operation Not Recommended					55.2	37.7	5.2	73.0	10.6
	11.5	2.0	4.7						58.2	38.7	4.7	74.4	12.3
	15.4	3.3	7.6						58.7	39.6	4.6	74.4	12.8
110	7.7	1.1	2.5	Operation Not Recommended					50.5	35.9	5.8	70.3	8.7
	11.5	2.0	4.5						53.9	36.8	5.3	71.8	10.2
	15.4	3.2	7.3						54.5	37.8	5.1	71.9	10.7

Interpolation is permissible; extrapolation is not.

Operation below 40°F EWT is based upon a 15% antifreeze solution.

All performance is based upon the lower voltage of dual voltage rated units.

Table does not reflect fan or pump power corrections for ARI/ISO conditions.

See performance correction tables for operating conditions other than those listed above.

Performance ISO 13256-1

Loading/ Capacity	Water Loop				Ground Water				Ground Loop			
	Heating 68°F EWT		Cooling 86°F EWT		Heating 50°F EWT		Cooling 59°F EWT		Heating 32/41°F EWT Full/Part		Cooling 77/68°F EWT Full/Part	
	kBtu/hr	COP	kBtu/hr	EER	kBtu/hr	COP	kBtu/hr	EER	kBtu/hr	COP	kBtu/hr	EER
Full	75.8	5.0	62.5	16.7	61.8	4.3	68.1	24.2	50.4	3.9	64.9	19.2

Electrical Specification

Voltage	Elect. Symbol	Compressor		Source Pump	Fan Motor FLA	HWG Pump FLA	Total Unit FLA	Min. Ampacity*	Max. Fuse/ Breaker*
		RLA	LRA						
208/230-1-60	1	26.3	150	3.0	6.8	0.4	36.5	43.1	65
200/230-3-60	2	17.6	120	3.0	6.8	0.4	27.8	32.2	45
460-3-60	3	8.3	70	3.0	6.8	0.4	18.5	20.6	25

*Where calculations are based on:

MCA = 1.25 x RLA compressor + Fan FLA + Pump FLA

MOP = 2.25 x RLA largest compressor + 1.00 x FLA other motors

Ensure that all loads on the supply line are added into the equations above if some of the cells in the above table are blank

GeoFurnace works continually to improve its products. As a result, the design and specifications of each product at the time of order may be changed without notice. Please contact GeoFurnace at 1-605-854-9205 for latest design and specifications. Purchaser's approval of this data set signifies that the equipment is acceptable under the provisions of the job specification. Statements and other information contained herein are not express warranties and do not form the basis of any contract between the parties, but are merely GeoFurnace's opinion or commendation of its products.

Rev: 8 April, 2010 - GFM-AJS

6 Ton - Single Stage Forced Air Submittal/Performance Data

Project: _____ Date: _____
 Engineer: _____ Unit No. _____
 Contractor: _____ PO: _____



MA071S Series - R410A

Magnum Series

Rated Airflow: 2100 Heating / 2100 Cooling

Water Source Heat Pump

EWT °F	WATER/BRINE			Heating - EAT 70°F					Cooling - EAT 80/67°F				
	FLOW gpm	PD psi	PD ft.	HC kBtu/hr	Pwr kW	HE kBtu/hr	LAT °F	COP	TC kBtu/hr	SC kBtu/hr	Pwr kW	HR kBtu/hr	EER
20	9.0	1.6	3.6	42.4	4.2	28.2	88.7	3.0	Operation Not Recommended				
	13.5	3.1	7.1										
	18.0	5.0	11.6										
30	9.0	1.6	3.8	46.0	4.3	31.5	90.3	3.2	77.9	48.7	2.5	86.5	31.0
	13.5	3.0	6.9	51.4	4.3	36.7	92.7	3.5	79.5	49.8	2.3	87.4	34.6
	18.0	4.9	11.2										
40	9.0	1.3	2.9	56.0	4.4	41.1	94.7	3.8	75.5	48.2	3.1	86.0	24.5
	13.5	2.5	5.8	57.8	4.4	42.8	95.5	3.8	77.7	49.4	2.8	87.2	27.9
	18.0	4.1	9.4	59.7	4.5	44.5	96.3	3.9	78.8	50.5	2.6	87.7	30.4
50	9.0	1.2	2.8	62.6	4.5	47.2	97.6	4.1	74.7	48.6	3.4	86.3	22.0
	13.5	2.4	5.6	65.3	4.6	49.8	98.8	4.2	76.9	49.7	3.1	87.4	25.0
	18.0	3.9	9.1	67.4	4.6	51.6	99.7	4.3	77.8	50.8	2.9	87.7	26.7
60	9.0	1.2	2.7	69.6	4.7	53.6	100.7	4.3	73.3	48.5	3.7	86.1	19.6
	13.5	2.3	5.4	73.3	4.7	57.2	102.3	4.5	75.6	49.6	3.4	87.2	22.2
	18.0	3.8	8.8	75.6	4.8	59.3	103.3	4.6	76.3	50.7	3.3	87.4	23.4
70	9.0	1.2	2.7	76.9	4.9	60.3	103.9	4.6	71.3	47.9	4.1	85.4	17.2
	13.5	2.3	5.2	81.9	4.9	65.2	106.1	4.9	73.7	49.1	3.8	86.6	19.6
	18.0	3.7	8.5	84.4	4.9	67.5	107.2	5.0	74.2	50.2	3.6	86.6	20.4
80	9.0	1.1	2.6	84.5	5.1	67.3	107.3	4.9	68.5	47.0	4.6	84.1	15.0
	13.5	2.2	5.1	91.0	5.1	73.7	110.1	5.3	71.2	48.2	4.2	85.4	17.1
	18.0	3.6	8.3	93.7	5.1	76.2	111.3	5.3	71.6	49.3	4.0	85.4	17.7
90	9.0	1.1	2.5	92.6	5.3	74.7	110.8	5.2	65.0	45.7	5.0	82.2	12.9
	13.5	2.1	4.9	100.8	5.3	82.8	114.4	5.6	67.9	46.8	4.6	83.6	14.8
	18.0	3.5	8.0	103.7	5.3	85.5	115.7	5.7	68.4	48.0	4.5	83.6	15.3
100	9.0	1.0	2.4	Operation Not Recommended					60.7	44.0	5.6	79.7	10.9
	13.5	2.0	4.7						63.9	45.1	5.1	81.3	12.6
	18.0	3.3	7.7						64.5	46.2	5.0	81.4	13.0
110	9.0	1.0	2.3	Operation Not Recommended					55.5	41.8	6.2	76.5	9.0
	13.5	2.0	4.5						59.2	43.0	5.6	78.4	10.5
	18.0	3.2	7.4						59.9	44.1	5.5	78.6	10.9

Interpolation is permissible; extrapolation is not.
 Operation below 40°F EWT is based upon a 15% antifreeze solution.
 All performance is based upon the lower voltage of dual voltage rated units.
 Table does not reflect fan or pump power corrections for ARI/ISO conditions.
 See performance correction tables for operating conditions other than those listed above.

Performance ISO 13256-1

Loading/ Capacity	Water Loop				Ground Water				Ground Loop			
	Heating 68°F EWT		Cooling 86°F EWT		Heating 50°F EWT		Cooling 59°F EWT		Heating 32/41°F EWT Full/Part		Cooling 77/68°F EWT Full/Part	
	kBtu/hr	COP	kBtu/hr	EER	kBtu/hr	COP	kBtu/hr	EER	kBtu/hr	COP	kBtu/hr	EER
Full	83.0	5.1	68.6	17.0	67.7	4.4	74.8	24.2	54.1	3.8	71.3	19.3

Electrical Specification

Voltage	Elect. Symbol	Compressor		Source Pump	Fan Motor FLA	HWG Pump FLA	Total Unit FLA	Min. Ampacity*	Max. Fuse/ Breaker*
		RLA	LRA						
208/230-1-60	1	30.1	145	3.0	9.1	0.4	42.6	50.1	80
200/230-3-60	2	17.6	120	3.0	9.1	0.4	30.1	34.5	50
460-3-60	3	9.6	70	3.0	9.1	0.4	22.1	24.5	30

*Where calculations are based on:

MCA = 1.25 x RLA compressor + Fan FLA + Pump FLA

MOP = 2.25 x RLA largest compressor + 1.00 x FLA other motors

Ensure that all loads on the supply line are added into the equations above if some of the cells in the above table are blank

GeoFurnace works continually to improve its products. As a result, the design and specifications of each product at the time of order may be changed without notice. Please contact GeoFurnace at 1-605-854-9205 for latest design and specifications. Purchaser's approval of this data set signifies that the equipment is acceptable under the provisions of the job specification. Statements and other information contained herein are not express warranties and do not form the basis of any contract between the parties, but are merely GeoFurnace's opinion or commendation of its products.

Two Stage Water to Air Submittal/Performance Data

Project: _____ Date: _____
Engineer: _____ Unit No. _____
Contractor: _____ PO. _____



GeoFurnace Manufacturing

Magnum Water Source Heat Pump

(MA-T) Two Stage Water to Air Submittal Data

**Models MA 026-071T
60 Hz - R410A**

2 - 6 Ton - 2 Stage Forced Air Performance Summary

Project: _____ Date: _____
 Engineer: _____ Unit No. _____
 Contractor: _____ PO: _____



2 Stage Forced Air - R410A Performance ISO 13256-1

Magnum Series Water Source Heat Pump

Model	Loading/ Capacity	Water Loop				Ground Water				Ground Loop			
		Heating 68°F EWT		Cooling 86°F EWT		Heating 50°F EWT		Cooling 59°F EWT		Heating 32/41°F EWT Full/Part		Cooling 77/68°F EWT Full/Part	
		kBtu/hr	COP	kBtu/hr	EER	kBtu/hr	COP	kBtu/hr	EER	kBtu/hr	COP	kBtu/hr	EER
26	Full	31.4	5.2	26.7	16.7	25.6	4.6	29.3	23.8	20.5	3.9	27.8	19.0
	Part	23.0	5.6	20.0	16.9	18.3	4.7	22.1	27.5	14.5	4.2	20.9	23.2
38	Full	45.1	4.8	36.8	15.9	37.0	4.3	40.2	22.0	29.7	3.8	38.2	17.9
	Part	31.4	5.8	27.5	17.8	25.3	4.8	29.9	27.8	20.1	4.2	28.6	24.2
50	Full	60.0	4.9	49.4	16.3	49.2	4.4	53.9	22.2	39.5	3.9	51.3	18.4
	Part	43.5	5.9	38.1	18.1	35.2	4.9	41.3	28.1	28.2	4.3	39.5	24.5
62	Full	75.5	4.9	62.4	15.6	62.0	4.4	68.5	21.9	47.1	3.7	65.0	17.7
	Part	54.8	5.8	47.8	17.5	44.1	4.8	52.4	28.0	35.0	4.2	49.7	23.8
71	Full	86.5	4.9	70.9	16.1	70.7	4.3	77.0	21.8	54.7	3.7	73.6	18.0
	Part	65.0	5.8	57.0	17.9	52.2	4.7	61.7	27.4	41.8	4.0	59.0	24.1

Heating capacity is based on entering air temperature of 68 dry bulb / 59 wet bulb
 Cooling capacity based on entering air temperature of 80.6 dry bulb / 66.2 wet bulb
 Operation below 40°F EWT is based upon a 15% antifreeze solution.
 All performance is based upon the lower voltage of dual voltage rated units.

2/9/2010

Electrical Specifications

Model	Voltage	Elect. Symbol	Compressor		Source Pump	Fan Motor FLA	HWG Pump FLA	Total Unit FLA	Min. Ampacity*	Max. Fuse/ Breaker*
			RLA	LRA						
26	208/230-1-60	1	10.3	52.0	1.5	4.3	0.4	16.5	19.1	25.0
	200/230-3-60	2	7.1	59.0	1.5	4.3	0.4	13.3	15.1	20.0
	460-3-60	3	3.5	29.7	1.5	4.3	0.4	9.7	10.6	15.0
38	208/230-1-60	1	16.7	82.0	1.5	4.3	0.4	22.9	27.1	40.0
	200/230-3-60	2	11.2	58.0	1.5	4.3	0.4	17.4	20.2	30.0
	460-3-60	3	4.5	29.0	1.5	4.3	0.4	10.7	11.8	15.0
50	208/230-1-60	1	21.2	96.0	3.0	4.3	0.4	28.9	34.2	55.0
	200/230-3-60	2	13.5	88.0	3.0	4.3	0.4	21.2	24.6	35.0
	460-3-60	3	6.4	41.0	3.0	4.3	0.4	14.1	15.7	20.0
62	208/230-1-60	1	25.6	118.0	3.0	6.8	0.4	35.8	42.2	65.0
	200/230-3-60	2	17.6	123.0	3.0	6.8	0.4	27.8	32.2	45.0
	460-3-60	3	9.0	62.0	3.0	6.8	0.4	19.2	21.5	30.0
71	208/230-1-60	1	27.2	150.0	3.0	9.1	0.4	39.7	46.5	70.0
	200/230-3-60	2	19.7	123.0	3.0	9.1	0.4	32.2	37.1	55.0
	460-3-60	3	9.9	62.0	3.0	9.1	0.4	22.4	24.9	30.0

*Where calculations are based on:

MCA = 1.25 x RLA compressor + FLA other motors

MOP = 2.25 x RLA largest compressor + 1.00 x FLA other motors

Ensure that all loads on the supply line are added into the equations above if some of the cells in the above table are blank

HACR circuit breaker for use in USA only. All fuses Class RK-5

For #N/A, the specified voltage is NOT available

4/1/2010

Pressure Drop Specifications

Model	GPM	Pressure Drop (psi)*						
		Entering Water Temperature °F						
		20	30	50	70	90	110	120
26	3.6	3.1	3.0	2.2	2.0	1.9	1.7	1.7
	5.4	4.5	4.3	3.1	2.9	2.7	2.5	2.4
	7.1	6.3	6.1	4.4	4.1	3.8	3.6	3.4
38	4.5	1.9	1.9	1.3	1.3	1.2	1.1	1.0
	6.8	2.4	2.3	1.7	1.6	1.4	1.3	1.3
	9.0	3.2	3.1	2.2	2.1	2.0	1.8	1.8
50	6.0	2.0	1.9	1.4	1.3	1.2	1.1	1.1
	9.0	3.9	3.8	2.7	2.5	2.4	2.2	2.1
	12.0	6.2	6.0	4.3	4.0	3.7	3.5	3.3
62	7.5	1.8	1.8	1.3	1.2	1.1	1.0	1.0
	11.3	3.3	3.2	2.3	2.2	2.0	1.9	1.8
	15.0	5.4	5.2	3.7	3.5	3.3	3.0	2.9
71	9.0	1.8	1.7	1.2	1.2	1.1	1.0	1.0
	13.5	3.5	3.4	2.4	2.3	2.1	2.0	1.9
	18.0	5.7	5.5	3.9	3.7	3.5	3.2	3.1

*Pressure drop thru each coaxial heat exchanger - below 40°F based on 23% PG

4/6/2010

GeoFurnace works continually to improve its products. As a result, the design and specifications of each product at the time of order may be changed without notice. Please contact GeoFurnace at 1-605-854-9205 for latest design and specifications. Purchaser's approval of this data set signifies that the equipment is acceptable under the provisions of the job specification. Statements and other information contained herein are not express warranties and do not form the basis of any contract between the parties, but are merely GeoFurnace's opinion or commendation of its products.

Rev: 6 April, 2010 - GFM-AJS

2 Ton - 2 Stage Forced Air Submittal/Performance Data

Project: _____ Date: _____
 Engineer: _____ Unit No. _____
 Contractor: _____ PO. _____



Full Load

MA026T Series - R410A

Rated Airflow: 900 Heating / 850 Cooling

Magnum Series
Water Source Heat Pump

WATER/BRINE				Heating - EAT 70°F					Cooling - EAT 80/67°F				
EWT °F	FLOW gpm	PD psi	PD ft.	HC kBtu/hr	Pwr kW	HE kBtu/hr	LAT °F	COP	TC kBtu/hr	SC kBtu/hr	Pwr kW	HR kBtu/hr	EER
20	3.6	2.7	6.3	13.1	1.5	8.0	84.2	2.6	Operation Not Recommended				
	5.4	3.9	9.1										
	7.1	5.6	12.8										
30	3.6	2.9	6.7	17.1	1.5	11.9	88.7	3.3	28.6	15.6	1.0	32.1	28.0
	5.4	3.8	8.8	17.9	1.5	12.6	89.5	3.4	28.7	15.7	1.0	32.2	27.9
	7.1	5.4	12.5										
40	3.6	2.2	5.1	21.5	1.6	16.1	93.4	4.0	28.1	15.5	1.2	32.0	24.3
	5.4	3.2	7.4	22.3	1.6	16.9	94.2	4.1	28.7	15.9	1.1	32.5	26.1
	7.1	4.5	10.4	22.6	1.6	17.2	94.6	4.2	28.9	15.9	1.1	32.7	26.4
50	3.6	2.2	5.0	23.9	1.6	18.4	96.1	4.3	27.8	15.6	1.3	32.1	22.2
	5.4	3.1	7.1	25.1	1.6	19.5	97.4	4.5	28.6	16.0	1.2	32.6	23.9
	7.1	4.4	10.1	25.5	1.7	19.8	97.8	4.5	28.8	16.0	1.2	32.9	24.5
60	3.6	2.1	4.8	26.6	1.7	20.8	99.0	4.6	27.3	15.5	1.4	32.0	19.9
	5.4	3.0	6.9	28.2	1.7	22.3	100.7	4.8	28.1	15.9	1.3	32.6	21.6
	7.1	4.2	9.8	28.6	1.7	22.7	101.2	4.8	28.5	16.0	1.3	32.8	22.3
70	3.6	2.0	4.7	29.4	1.8	23.4	102.0	4.9	26.6	15.4	1.5	31.7	17.6
	5.4	2.9	6.7	31.5	1.8	25.3	104.3	5.1	27.4	15.8	1.4	32.3	19.2
	7.1	4.1	9.5	31.9	1.8	25.7	104.8	5.1	27.8	15.8	1.4	32.6	19.9
80	3.6	1.9	4.5	32.4	1.9	26.0	105.3	5.1	25.6	15.1	1.7	31.2	15.4
	5.4	2.8	6.5	35.0	1.9	28.5	108.2	5.4	26.4	15.4	1.6	31.8	16.8
	7.1	4.0	9.2	35.5	1.9	28.9	108.7	5.4	26.9	15.5	1.5	32.1	17.5
90	3.6	1.9	4.3	35.5	2.0	28.7	108.7	5.2	24.4	14.6	1.8	30.6	13.3
	5.4	2.7	6.3	38.8	2.0	31.8	112.2	5.6	25.2	15.0	1.7	31.1	14.6
	7.1	3.8	8.9	39.3	2.1	32.2	112.8	5.6	25.6	15.1	1.7	31.4	15.1
100	3.6	1.8	4.2	Operation Not Recommended					22.9	14.1	2.0	29.8	11.4
	5.4	2.6	6.0	Operation Not Recommended					23.8	14.4	1.9	30.3	12.4
	7.1	3.7	8.5	Operation Not Recommended					24.1	14.5	1.9	30.6	12.9
110	3.6	1.7	4.0	Operation Not Recommended					21.3	13.3	2.2	28.9	9.6
	5.4	2.5	5.8	Operation Not Recommended					22.2	13.7	2.1	29.4	10.5
	7.1	3.6	8.2	Operation Not Recommended					22.4	13.8	2.1	29.5	10.7

Part Load

Rated Airflow: 800 Heating / 700 Cooling

WATER/BRINE				Heating - EAT 70°F					Cooling - EAT 80/67°F				
EWT °F	FLOW gpm	PD psi	PD ft.	HC kBtu/hr	Pwr kW	HE kBtu/hr	LAT °F	COP	TC kBtu/hr	SC kBtu/hr	Pwr kW	HR kBtu/hr	EER
20	3.4	2.6	6.1	10.9	1.1	7.2	82.6	3.0	Operation Not Recommended				
	5.1	3.7	8.6										
	6.8	5.2	12.0										
30	3.4	2.8	6.4	13.7	1.1	10.0	85.9	3.7	21.3	16.4	0.6	23.3	35.3
	5.1	3.6	8.3	13.9	1.1	10.2	86.1	3.7	21.4	16.6	0.6	23.6	33.3
	6.8	5.0	11.7										
40	3.4	2.1	4.9	15.2	1.1	11.4	87.6	4.0	21.1	16.5	0.8	23.7	28.1
	5.1	3.0	7.0	15.8	1.1	11.9	88.2	4.1	21.5	16.6	0.7	23.9	31.0
	6.8	4.2	9.8	16.0	1.1	12.1	88.5	4.1	21.9	16.8	0.7	24.2	32.0
50	3.4	2.1	4.8	17.2	1.2	13.2	89.9	4.3	21.0	16.6	0.9	23.9	24.6
	5.1	2.9	6.8	18.0	1.2	14.0	90.8	4.5	21.4	16.8	0.8	24.1	27.1
	6.8	4.1	9.5	18.2	1.2	14.2	91.1	4.5	22.1	16.9	0.8	24.6	29.4
60	3.4	2.0	4.6	19.3	1.2	15.2	92.4	4.7	20.6	16.5	1.0	23.9	21.3
	5.1	2.8	6.6	20.4	1.2	16.3	93.6	5.0	21.1	16.7	0.9	24.1	23.4
	6.8	4.0	9.2	20.7	1.2	16.5	93.9	5.0	21.9	16.9	0.8	24.8	26.2
70	3.4	1.9	4.5	21.6	1.2	17.4	95.0	5.1	20.0	16.4	1.1	23.7	18.3
	5.1	2.7	6.3	23.0	1.2	18.8	96.7	5.4	20.5	16.5	1.0	24.0	20.1
	6.8	3.8	8.9	23.4	1.3	19.1	97.0	5.5	21.4	16.7	0.9	24.6	22.5
80	3.4	1.9	4.3	24.1	1.3	19.7	97.9	5.5	19.1	16.1	1.2	23.3	15.6
	5.1	2.7	6.1	25.9	1.3	21.5	100.0	5.9	19.7	16.2	1.1	23.6	17.1
	6.8	3.7	8.6	26.3	1.3	21.9	100.4	6.0	20.5	16.4	1.1	24.2	19.0
90	3.4	1.8	4.2	26.7	1.3	22.2	100.9	5.9	18.1	15.6	1.4	22.8	13.1
	5.1	2.6	5.9	29.1	1.3	24.5	103.6	6.4	18.6	15.8	1.3	23.0	14.4
	6.8	3.6	8.3	29.4	1.3	24.9	104.1	6.5	19.4	16.0	1.2	23.6	15.7
100	3.4	1.8	4.0	Operation Not Recommended					16.9	15.0	1.5	22.1	11.0
	5.1	2.5	5.7	Operation Not Recommended					17.5	15.2	1.4	22.4	12.0
	6.8	3.5	8.0	Operation Not Recommended					18.1	15.4	1.4	22.8	12.9
110	3.4	1.7	3.9	Operation Not Recommended					15.6	14.3	1.7	21.5	9.0
	5.1	2.4	5.5	Operation Not Recommended					16.2	14.5	1.6	21.7	9.9
	6.8	3.3	7.7	Operation Not Recommended					16.7	14.7	1.6	22.1	10.6

Interpolation is permissible; extrapolation is not.

Operation below 40°F EWT is based upon a 15% antifreeze solution.

All performance is based upon the lower voltage of dual voltage rated units.

Table does not reflect fan or pump power corrections for AR/ISO conditions.

See performance correction tables for operating conditions other than those listed above.

3 Ton - 2 Stage Forced Air Submittal/Performance Data

Project: _____ Date: _____
 Engineer: _____ Unit No. _____
 Contractor: _____ PO: _____



Full Load

MA038T Series - R410A

Rated Airflow: 1270 Heating / 1200 Cooling

Magnum Series
Water Source Heat Pump

WATER/BRINE				Heating - EAT 70°F					Cooling - EAT 80/67°F				
EWT °F	FLOW gpm	PD psi	PD ft.	HC kBtu/hr	Pwr kW	HE kBtu/hr	LAT °F	COP	TC kBtu/hr	SC kBtu/hr	Pwr kW	HR kBtu/hr	EER
20	4.5	1.7	3.9	24.9	2.2	17.4	89.2	3.3	Operation Not Recommended				
	6.8	2.1	4.9										
	9.0	2.8	6.6										
30	4.5	1.8	4.2	28.0	2.3	20.2	91.6	3.6	41.6	23.2	1.6	46.9	26.8
	6.8	2.0	4.7	28.9	2.3	21.0	92.3	3.7	42.2	23.7	1.5	47.2	29.1
	9.0	2.8	6.4										
40	4.5	1.4	3.2	30.7	2.4	22.7	93.7	3.8	40.6	23.0	1.8	46.8	22.1
	6.8	1.7	3.9	31.7	2.4	23.6	94.5	3.9	41.6	23.5	1.7	47.4	24.6
	9.0	2.3	5.3	32.8	2.4	24.5	95.3	3.9	42.1	24.1	1.6	47.6	26.3
50	4.5	1.3	3.1	34.3	2.5	25.8	96.5	4.1	40.1	23.1	2.0	46.9	20.1
	6.8	1.7	3.8	35.8	2.5	27.2	97.6	4.2	41.3	23.7	1.8	47.6	22.4
	9.0	2.2	5.2	36.9	2.6	28.1	98.5	4.2	41.7	24.2	1.8	47.7	23.7
60	4.5	1.3	3.0	38.0	2.6	29.1	99.3	4.3	39.4	23.1	2.2	46.8	18.1
	6.8	1.6	3.7	40.0	2.7	31.0	100.9	4.4	40.6	23.6	2.0	47.4	20.3
	9.0	2.2	5.0	41.2	2.7	32.1	101.8	4.5	40.9	24.2	1.9	47.5	21.2
70	4.5	1.3	2.9	41.9	2.7	32.6	102.4	4.5	38.2	22.8	2.4	46.3	16.1
	6.8	1.6	3.6	44.6	2.8	35.0	104.4	4.7	39.6	23.4	2.2	47.0	18.1
	9.0	2.1	4.9	45.8	2.8	36.2	105.4	4.7	39.8	23.9	2.1	47.1	18.8
80	4.5	1.2	2.8	46.0	2.9	36.1	105.5	4.7	36.7	22.4	2.6	45.6	14.1
	6.8	1.5	3.5	49.3	2.9	39.3	108.0	4.9	38.2	22.9	2.4	46.3	15.9
	9.0	2.0	4.7	50.6	3.0	40.5	109.1	5.0	38.4	23.5	2.3	46.3	16.5
90	4.5	1.2	2.7	50.1	3.0	39.7	108.7	4.8	34.9	21.8	2.9	44.7	12.2
	6.8	1.4	3.3	54.2	3.1	43.7	111.8	5.1	36.4	22.3	2.6	45.4	13.9
	9.0	2.0	4.5	55.6	3.1	45.0	112.9	5.2	36.7	22.8	2.6	45.4	14.3
100	4.5	1.1	2.6	Operation Not Recommended					32.8	20.9	3.2	43.7	10.3
	6.8	1.4	3.2						34.4	21.5	2.9	44.3	11.9
	9.0	1.9	4.4						34.7	22.0	2.8	44.3	12.3
110	4.5	1.1	2.5	Operation Not Recommended					30.4	19.9	3.5	42.4	8.6
	6.8	1.3	3.1						32.1	20.5	3.2	43.0	10.0
	9.0	1.8	4.2						32.4	21.0	3.1	43.0	10.4

Part Load

Rated Airflow: 1100 Heating / 1000 Cooling

WATER/BRINE				Heating - EAT 70°F					Cooling - EAT 80/67°F				
EWT °F	FLOW gpm	PD psi	PD ft.	HC kBtu/hr	Pwr kW	HE kBtu/hr	LAT °F	COP	TC kBtu/hr	SC kBtu/hr	Pwr kW	HR kBtu/hr	EER
20	4.2	1.7	3.9	Operation Not Recommended					Operation Not Recommended				
	6.3	2.0	4.6										
	8.5	2.6	6.1										
30	4.2	1.8	4.1	18.9	1.5	13.8	85.9	3.7	28.8	23.4	0.9	31.9	32.6
	6.3	1.9	4.5	19.2	1.5	14.0	86.2	3.7	28.9	23.7	0.9	32.1	31.3
	8.5	2.6	5.9										
40	4.2	1.4	3.1	21.0	1.5	15.7	87.7	4.0	28.6	23.5	1.0	32.2	27.4
	6.3	1.6	3.8	21.8	1.6	16.4	88.3	4.1	29.1	23.8	1.0	32.4	29.7
	8.5	2.1	4.9	22.1	1.6	16.7	88.6	4.1	29.6	24.1	1.0	32.9	30.7
50	4.2	1.3	3.0	23.7	1.6	18.3	90.0	4.4	28.5	23.7	1.2	32.5	24.6
	6.3	1.6	3.6	24.8	1.6	19.4	90.9	4.6	29.0	23.9	1.1	32.7	26.7
	8.5	2.1	4.8	25.1	1.6	19.7	91.2	4.6	29.8	24.2	1.0	33.3	28.8
60	4.2	1.3	3.0	26.6	1.6	21.1	92.4	4.8	28.1	23.6	1.3	32.5	21.9
	6.3	1.5	3.5	28.1	1.6	22.6	93.6	5.1	28.7	23.9	1.2	32.8	23.8
	8.5	2.0	4.6	28.4	1.6	22.9	93.9	5.1	29.7	24.2	1.1	33.5	26.3
70	4.2	1.2	2.9	29.7	1.6	24.1	95.0	5.3	27.4	23.4	1.4	32.3	19.1
	6.3	1.5	3.4	31.6	1.6	26.0	96.6	5.7	28.0	23.6	1.3	32.6	20.8
	8.5	1.9	4.5	32.0	1.6	26.4	96.9	5.7	29.1	23.9	1.3	33.4	23.2
80	4.2	1.2	2.8	32.9	1.7	27.2	97.7	5.8	26.4	22.9	1.6	31.9	16.4
	6.3	1.4	3.3	35.3	1.6	29.7	99.7	6.3	27.1	23.2	1.5	32.2	18.0
	8.5	1.9	4.3	35.7	1.6	30.1	100.0	6.4	28.1	23.5	1.4	32.9	19.8
90	4.2	1.2	2.7	36.3	1.7	30.6	100.5	6.4	25.1	22.3	1.8	31.2	13.9
	6.3	1.4	3.2	39.1	1.6	33.6	102.9	7.1	25.8	22.6	1.7	31.6	15.3
	8.5	1.8	4.2	39.6	1.6	34.0	103.3	7.1	26.8	22.8	1.6	32.3	16.6
100	4.2	1.1	2.6	Operation Not Recommended					23.5	21.5	2.0	30.4	11.5
	6.3	1.3	3.1						24.3	21.7	1.9	30.8	12.7
	8.5	1.8	4.0						25.1	22.0	1.8	31.4	13.6
110	4.2	1.1	2.5	Operation Not Recommended					21.6	20.5	2.3	29.4	9.4
	6.3	1.3	3.0						22.4	20.7	2.2	29.8	10.4
	8.5	1.7	3.9						23.2	21.0	2.1	30.4	11.1

Interpolation is permissible; extrapolation is not.
 Operation below 40°F EWT is based upon a 15% antifreeze solution.
 All performance is based upon the lower voltage of dual voltage rated units.
 Table does not reflect fan or pump power corrections for AR/ISO conditions.
 See performance correction tables for operating conditions other than those listed above.

4 Ton - 2 Stage Forced Air Submittal/Performance Data

Project: _____ Date: _____
 Engineer: _____ Unit No. _____
 Contractor: _____ PO: _____



Full Load

MA050T Series - R410A

Rated Airflow: 1600 Heating / 1550 Cooling

Magnum Series
Water Source Heat Pump

WATER/BRINE				Heating - EAT 70°F					Cooling - EAT 80/67°F				
EWT °F	FLOW gpm	PD psi	PD ft.	HC kBtu/hr	Pwr kW	HE kBtu/hr	LAT °F	COP	TC kBtu/hr	SC kBtu/hr	Pwr kW	HR kBtu/hr	EER
20	6.0	1.8	4.1	31.7	2.9	21.8	88.9	3.2	Operation Not Recommended				
	9.0	3.4	7.9										
	12.0	5.4	12.5										
30	6.0	1.9	4.3	31.8	3.0	21.6	89.0	3.1	55.9	27.8	2.1	63.0	26.9
	9.0	3.3	7.7	38.4	3.0	28.0	92.9	3.7	56.8	28.5	1.9	63.5	29.3
	12.0	5.3	12.1										
40	6.0	1.4	3.3	38.5	3.1	28.0	93.0	3.7	54.4	27.6	2.4	62.7	22.3
	9.0	2.8	6.4	42.1	3.1	31.4	95.2	3.9	55.9	28.2	2.3	63.6	24.7
	12.0	4.4	10.2	43.5	3.2	32.6	96.0	4.0	56.6	28.9	2.1	63.9	26.4
50	6.0	1.4	3.2	45.5	3.2	34.5	97.2	4.1	53.8	27.7	2.6	62.9	20.4
	9.0	2.7	6.3	47.5	3.3	36.3	98.4	4.2	55.4	28.4	2.4	63.8	22.6
	12.0	4.3	9.9	49.0	3.3	37.6	99.3	4.3	56.0	29.0	2.3	64.0	23.8
60	6.0	1.3	3.1	50.5	3.4	38.9	100.2	4.4	52.8	27.7	2.9	62.6	18.5
	9.0	2.6	6.1	53.2	3.5	41.5	101.8	4.5	54.5	28.3	2.7	63.5	20.5
	12.0	4.1	9.5	54.8	3.5	42.9	102.8	4.6	54.9	29.0	2.6	63.7	21.5
70	6.0	1.3	3.0	55.7	3.6	43.6	103.3	4.6	51.3	27.4	3.1	61.9	16.5
	9.0	2.5	5.9	59.3	3.6	46.9	105.4	4.8	53.1	28.0	2.9	62.9	18.5
	12.0	4.0	9.2	61.0	3.7	48.5	106.4	4.9	53.4	28.7	2.8	63.0	19.2
80	6.0	1.3	2.9	61.1	3.8	48.3	106.5	4.8	49.3	26.9	3.4	60.8	14.5
	9.0	2.5	5.7	65.6	3.8	52.6	109.2	5.1	51.2	27.5	3.1	61.9	16.4
	12.0	3.9	8.9	67.4	3.8	54.3	110.3	5.1	51.5	28.2	3.0	61.9	16.9
90	6.0	1.2	2.8	66.6	3.9	53.2	109.8	5.0	46.8	26.1	3.7	59.5	12.5
	9.0	2.4	5.5	72.1	4.0	58.5	113.1	5.3	48.9	26.8	3.4	60.5	14.3
	12.0	3.7	8.6	74.1	4.0	60.3	114.2	5.4	49.2	27.4	3.3	60.5	14.8
100	6.0	1.2	2.7	Operation Not Recommended					43.8	25.1	4.1	57.8	10.6
	9.0	2.3	5.3						46.0	25.8	3.8	58.9	12.2
	12.0	3.6	8.3						46.4	26.4	3.7	58.9	12.7
110	6.0	1.1	2.6	Operation Not Recommended					40.3	23.9	4.6	56.0	8.8
	9.0	2.2	5.1						42.8	24.6	4.2	57.0	10.3
	12.0	3.5	8.0						43.2	25.2	4.0	57.0	10.7

Part Load

Rated Airflow: 1300 Heating / 1200 Cooling

WATER/BRINE				Heating - EAT 70°F					Cooling - EAT 80/67°F				
EWT °F	FLOW gpm	PD psi	PD ft.	HC kBtu/hr	Pwr kW	HE kBtu/hr	LAT °F	COP	TC kBtu/hr	SC kBtu/hr	Pwr kW	HR kBtu/hr	EER
20	5.6	1.6	3.6	23.5	2.0	16.7	86.8	3.4	Operation Not Recommended				
	8.5	3.1	7.2										
	11.3	4.9	11.3										
30	5.6	1.7	3.9	26.7	2.1	19.6	89.0	3.8	39.9	28.1	1.2	44.0	33.1
	8.5	3.0	7.0	27.0	2.1	20.0	89.3	3.8	40.0	28.5	1.3	44.3	31.7
	11.3	4.8	11.0										
40	5.6	1.3	3.0	29.5	2.1	22.3	91.0	4.1	39.6	28.2	1.4	44.5	27.8
	8.5	2.5	5.8	30.5	2.1	23.2	91.7	4.2	40.2	28.5	1.3	44.8	30.1
	11.3	4.0	9.2	30.9	2.1	23.6	92.0	4.2	40.9	28.9	1.3	45.4	31.1
50	5.6	1.2	2.9	33.1	2.2	25.8	93.6	4.5	39.4	28.4	1.6	44.8	25.0
	8.5	2.5	5.7	34.6	2.2	27.2	94.6	4.7	40.1	28.7	1.5	45.2	27.1
	11.3	3.9	8.9	35.0	2.2	27.6	94.9	4.7	41.2	29.0	1.4	46.0	29.2
60	5.6	1.2	2.8	37.0	2.2	29.5	96.4	4.9	38.9	28.3	1.8	44.9	22.2
	8.5	2.4	5.5	39.0	2.2	31.4	97.8	5.2	39.6	28.7	1.6	45.3	24.1
	11.3	3.7	8.7	39.5	2.2	31.9	98.1	5.2	41.0	29.0	1.5	46.3	26.7
70	5.6	1.2	2.7	41.2	2.2	33.5	99.3	5.4	37.9	28.0	2.0	44.6	19.4
	8.5	2.3	5.3	43.7	2.2	36.1	101.1	5.7	38.8	28.4	1.8	45.0	21.1
	11.3	3.6	8.4	44.2	2.2	36.6	101.5	5.8	40.2	28.7	1.7	46.1	23.5
80	5.6	1.1	2.6	45.5	2.3	37.7	102.4	5.9	36.6	27.5	2.2	44.1	16.7
	8.5	2.2	5.1	48.6	2.2	41.0	104.6	6.4	37.5	27.8	2.1	44.5	18.2
	11.3	3.5	8.1	49.2	2.2	41.6	105.1	6.4	38.9	28.2	1.9	45.5	20.1
90	5.6	1.1	2.5	50.0	2.3	42.2	105.6	6.4	34.8	26.8	2.5	43.2	14.1
	8.5	2.1	5.0	53.9	2.2	46.3	108.4	7.1	35.8	27.1	2.3	43.7	15.5
	11.3	3.4	7.8	54.5	2.2	46.9	108.8	7.2	37.1	27.4	2.2	44.6	16.8
100	5.6	1.0	2.4	Operation Not Recommended					32.7	25.8	2.8	42.1	11.7
	8.5	2.1	4.8						33.7	26.1	2.6	42.6	12.9
	11.3	3.3	7.5						34.8	26.4	2.5	43.4	13.8
110	5.6	1.0	2.3	Operation Not Recommended					30.1	24.6	3.1	40.8	9.6
	8.5	2.0	4.6						31.3	24.9	3.0	41.4	10.6
	11.3	3.1	7.3						32.3	25.2	2.9	42.1	11.3

Interpolation is permissible; extrapolation is not.
 Operation below 40°F EWT is based upon a 15% antifreeze solution.
 All performance is based upon the lower voltage of dual voltage rated units.
 Table does not reflect fan or pump power corrections for AR/ISO conditions.
 See performance correction tables for operating conditions other than those listed above.

5 Ton - 2 Stage Forced Air Submittal/Performance Data

Project: _____ Date: _____
 Engineer: _____ Unit No. _____
 Contractor: _____ PO: _____



Full Load

MA062T Series - R410A

Rated Airflow: 2000 Heating / 1850 Cooling

Magnum Series

Water Source Heat Pump

WATER/BRINE				Heating - EAT 70°F					Cooling - EAT 80/67°F				
EWT °F	FLOW gpm	PD psi	PD ft.	HC kBtu/hr	Pwr kW	HE kBtu/hr	LAT °F	COP	TC kBtu/hr	SC kBtu/hr	Pwr kW	HR kBtu/hr	EER
20	7.5	1.6	3.7	38.0	3.7	25.4	89.0	3.0	Operation Not Recommended				
	11.3	2.9	6.8										
	15.0	4.7	10.9										
30	7.5	1.7	3.9	44.9	3.8	32.0	92.5	3.5	70.8	38.0	2.7	80.1	26.0
	11.3	2.8	6.6	47.9	3.9	34.8	94.0	3.6	70.2	38.8	2.7	79.5	25.8
	15.0	4.6	10.6										
40	7.5	1.3	3.0	51.3	3.9	37.9	95.7	3.8	69.3	37.7	3.1	80.1	22.0
	11.3	2.4	5.5	53.0	4.0	39.4	96.5	3.9	70.8	38.5	2.9	80.8	24.0
	15.0	3.8	8.9	54.8	4.0	41.0	97.4	4.0	70.5	39.3	2.9	80.4	24.2
50	7.5	1.3	2.9	57.4	4.1	43.4	98.7	4.1	68.5	37.9	3.4	80.2	20.0
	11.3	2.3	5.3	59.9	4.2	45.7	100.0	4.2	70.0	38.7	3.2	80.9	21.8
	15.0	3.7	8.6	61.8	4.2	47.4	100.9	4.3	70.1	39.5	3.1	80.8	22.4
60	7.5	1.2	2.8	63.7	4.3	49.1	101.9	4.4	67.0	37.8	3.7	79.8	17.9
	11.3	2.2	5.2	67.1	4.3	52.3	103.6	4.5	68.6	38.7	3.5	80.6	19.6
	15.0	3.6	8.3	69.1	4.4	54.1	104.6	4.6	69.0	39.5	3.4	80.6	20.3
70	7.5	1.2	2.8	70.2	4.5	54.9	105.2	4.6	64.9	37.5	4.1	78.9	15.9
	11.3	2.2	5.0	74.6	4.6	59.1	107.3	4.8	66.7	38.3	3.8	79.7	17.4
	15.0	3.5	8.1	76.7	4.6	60.9	108.4	4.9	67.2	39.1	3.7	79.9	18.2
80	7.5	1.2	2.7	76.8	4.7	60.7	108.5	4.8	62.2	36.8	4.5	77.5	13.8
	11.3	2.1	4.8	82.2	4.8	65.9	111.1	5.0	64.1	37.6	4.2	78.5	15.3
	15.0	3.4	7.8	84.4	4.9	67.8	112.2	5.1	64.8	38.5	4.1	78.6	16.0
90	7.5	1.1	2.6	83.4	5.0	66.5	111.8	4.9	58.8	35.9	5.0	75.8	11.8
	11.3	2.0	4.7	89.9	5.0	72.7	115.0	5.2	61.0	36.7	4.6	76.8	13.2
	15.0	3.3	7.5	92.1	5.1	74.6	116.1	5.3	61.6	37.5	4.5	76.9	13.8
100	7.5	1.1	2.5	Operation Not Recommended					54.9	34.6	5.5	73.7	10.0
	11.3	1.9	4.5						57.2	35.5	5.1	74.7	11.2
	15.0	3.1	7.3						57.8	36.3	5.0	74.7	11.6
110	7.5	1.0	2.4	Operation Not Recommended					50.4	33.1	6.1	71.3	8.2
	11.3	1.9	4.3						52.9	33.9	5.7	72.3	9.3
	15.0	3.0	7.0						53.2	34.7	5.6	72.2	9.5

Part Load

Rated Airflow: 1600 Heating / 1500 Cooling

WATER/BRINE				Heating - EAT 70°F					Cooling - EAT 80/67°F				
EWT °F	FLOW gpm	PD psi	PD ft.	HC kBtu/hr	Pwr kW	HE kBtu/hr	LAT °F	COP	TC kBtu/hr	SC kBtu/hr	Pwr kW	HR kBtu/hr	EER
20	7.0	1.5	3.4	Operation Not Recommended					Operation Not Recommended				
	10.5	2.6	6.1										
	14.0	4.2	9.7										
30	7.0	1.6	3.6	33.0	2.6	24.0	89.1	3.7	51.8	35.2	1.4	56.6	36.4
	10.5	2.6	5.9	33.5	2.7	24.5	89.4	3.7	51.7	35.6	1.5	56.8	34.1
	14.0	4.1	9.4										
40	7.0	1.2	2.8	36.7	2.7	27.5	91.2	4.0	50.6	35.3	1.8	56.6	28.5
	10.5	2.1	4.9	38.0	2.7	28.7	92.0	4.1	51.6	35.7	1.6	57.2	31.6
	14.0	3.4	7.9	38.5	2.7	29.2	92.3	4.2	52.5	36.1	1.6	58.0	32.8
50	7.0	1.2	2.7	41.4	2.7	32.1	94.0	4.4	50.0	35.5	2.0	56.8	25.0
	10.5	2.1	4.8	43.3	2.8	33.9	95.1	4.6	51.1	35.9	1.9	57.4	27.5
	14.0	3.3	7.6	43.9	2.8	34.4	95.4	4.6	52.6	36.3	1.8	58.6	29.9
60	7.0	1.1	2.6	46.5	2.8	36.9	96.9	4.9	49.0	35.4	2.3	56.7	21.8
	10.5	2.0	4.6	49.0	2.8	39.4	98.3	5.1	50.1	35.8	2.1	57.3	23.9
	14.0	3.2	7.4	49.6	2.8	40.0	98.7	5.1	52.0	36.2	2.0	58.7	26.7
70	7.0	1.1	2.5	51.8	2.9	42.0	100.0	5.3	47.7	35.1	2.5	56.3	18.9
	10.5	1.9	4.5	55.0	2.9	45.2	101.8	5.6	48.8	35.5	2.4	56.9	20.7
	14.0	3.1	7.2	55.7	2.9	45.8	102.2	5.7	50.7	35.9	2.2	58.3	23.0
80	7.0	1.1	2.4	57.3	2.9	47.3	103.2	5.7	45.8	34.4	2.8	55.5	16.2
	10.5	1.9	4.3	61.3	2.9	51.3	105.5	6.1	47.1	34.8	2.7	56.1	17.7
	14.0	3.0	6.9	62.0	2.9	52.0	105.9	6.2	48.9	35.2	2.5	57.4	19.5
90	7.0	1.0	2.3	63.0	3.0	52.7	106.5	6.1	43.6	33.5	3.2	54.4	13.7
	10.5	1.8	4.2	67.9	3.0	57.6	109.3	6.6	44.9	33.9	3.0	55.0	15.1
	14.0	2.9	6.7	68.7	3.0	58.3	109.7	6.7	46.5	34.3	2.8	56.2	16.3
100	7.0	1.0	2.3	Operation Not Recommended					40.8	32.2	3.6	52.9	11.5
	10.5	1.7	4.0						42.2	32.6	3.3	53.6	12.6
	14.0	2.8	6.5						43.6	33.0	3.2	54.6	13.5
110	7.0	0.9	2.2	Operation Not Recommended					37.5	30.7	4.0	51.2	9.4
	10.5	1.7	3.9						39.0	31.1	3.8	51.9	10.4
	14.0	2.7	6.2						40.4	31.5	3.7	52.8	11.0

Interpolation is permissible; extrapolation is not.
 Operation below 40°F EWT is based upon a 15% antifreeze solution.
 All performance is based upon the lower voltage of dual voltage rated units.
 Table does not reflect fan or pump power corrections for AR/ISO conditions.
 See performance correction tables for operating conditions other than those listed above.

6 Ton - 2 Stage Forced Air Submittal/Performance Data

Project: _____ Date: _____
 Engineer: _____ Unit No. _____
 Contractor: _____ PO: _____



Full Load

MA071T Series - R410A

Rated Airflow: 2100 Heating / 2100 Cooling

Magnum Series

Water Source Heat Pump

WATER/BRINE				Heating - EAT 70°F					Cooling - EAT 80/67°F				
EWT °F	FLOW gpm	PD psi	PD ft.	HC kBtu/hr	Pwr kW	HE kBtu/hr	LAT °F	COP	TC kBtu/hr	SC kBtu/hr	Pwr kW	HR kBtu/hr	EER
20	9.0	1.6	3.6	42.9	4.3	28.2	88.9	2.9	Operation Not Recommended				
	13.5	3.1	7.1										
	18.0	5.0	11.6										
30	9.0	1.6	3.8	46.6	4.4	31.5	90.5	3.1	79.3	48.7	3.0	89.5	26.6
	13.5	3.0	6.9	52.0	4.5	36.7	92.9	3.4	80.4	49.8	2.8	89.9	29.1
	18.0	4.9	11.2										
40	9.0	1.3	2.9	57.0	4.6	41.5	95.1	3.7	77.6	48.2	3.5	89.7	21.9
	13.5	2.5	5.8	60.5	4.6	44.8	96.7	3.8	79.6	49.4	3.3	90.7	24.4
	18.0	4.1	9.4	62.4	4.7	46.5	97.5	3.9	80.5	50.5	3.1	91.0	26.1
50	9.0	1.2	2.8	65.4	4.7	49.2	98.8	4.0	77.0	48.6	3.9	90.1	20.0
	13.5	2.4	5.6	68.2	4.8	51.8	100.1	4.2	79.1	49.7	3.6	91.2	22.2
	18.0	3.9	9.1	70.4	4.9	53.8	101.0	4.2	79.8	50.8	3.4	91.4	23.5
60	9.0	1.2	2.7	72.6	4.9	55.7	102.0	4.3	75.6	48.5	4.2	89.9	18.1
	13.5	2.3	5.4	76.6	5.0	59.5	103.8	4.5	77.9	49.6	3.9	91.1	20.2
	18.0	3.8	8.8	78.9	5.1	61.6	104.8	4.6	78.5	50.7	3.7	91.2	21.1
70	9.0	1.2	2.7	80.2	5.2	62.6	105.4	4.6	73.6	47.9	4.5	89.1	16.2
	13.5	2.3	5.2	85.4	5.2	67.6	107.7	4.8	76.0	49.1	4.2	90.4	18.1
	18.0	3.7	8.5	88.0	5.3	69.9	108.8	4.9	76.5	50.2	4.1	90.4	18.8
80	9.0	1.1	2.6	88.2	5.4	69.8	108.9	4.8	70.8	47.0	4.9	87.7	14.4
	13.5	2.2	5.1	94.8	5.5	76.2	111.8	5.1	73.5	48.2	4.6	89.1	16.1
	18.0	3.6	8.3	97.6	5.5	78.7	113.0	5.2	73.9	49.3	4.4	89.1	16.6
90	9.0	1.1	2.5	96.5	5.7	77.2	112.5	5.0	67.4	45.7	5.4	85.8	12.6
	13.5	2.1	4.9	104.7	5.7	85.2	116.2	5.4	70.3	46.8	5.0	87.2	14.2
	18.0	3.5	8.0	107.7	5.8	87.9	117.5	5.4	70.7	48.0	4.8	87.2	14.6
100	9.0	1.0	2.4	Operation Not Recommended					63.4	44.0	5.9	83.4	10.8
	13.5	2.0	4.7						66.4	45.1	5.4	84.9	12.3
	18.0	3.3	7.7						66.9	46.2	5.3	84.9	12.7
110	9.0	1.0	2.3	Operation Not Recommended					58.8	41.8	6.4	80.6	9.2
	13.5	2.0	4.5						61.9	43.0	5.9	82.1	10.5
	18.0	3.2	7.4						62.5	44.1	5.8	82.2	10.9

Part Load

Rated Airflow: 1650 Heating / 1550 Cooling

WATER/BRINE				Heating - EAT 70°F					Cooling - EAT 80/67°F				
EWT °F	FLOW gpm	PD psi	PD ft.	HC kBtu/hr	Pwr kW	HE kBtu/hr	LAT °F	COP	TC kBtu/hr	SC kBtu/hr	Pwr kW	HR kBtu/hr	EER
20	8.5	1.4	3.2	35.2	3.2	24.1	89.7	3.2	Operation Not Recommended				
	12.7	2.8	6.5										
	17.0	4.5	10.5										
30	8.5	1.5	3.4	39.6	3.3	28.5	92.2	3.6	59.8	36.3	1.8	65.9	33.5
	12.7	2.7	6.3	40.2	3.3	29.0	92.5	3.6	59.9	36.8	1.9	66.4	31.7
	17.0	4.4	10.2										
40	8.5	1.1	2.6	43.6	3.3	32.5	94.5	3.9	59.1	36.4	2.2	66.5	27.3
	12.7	2.3	5.3	45.1	3.3	33.9	95.3	4.0	60.1	36.9	2.0	67.0	29.8
	17.0	3.7	8.5	45.8	3.3	34.5	95.7	4.1	61.2	37.3	2.0	68.0	30.7
50	8.5	1.1	2.5	49.1	3.3	37.8	97.6	4.3	58.8	36.7	2.4	67.1	24.4
	12.7	2.2	5.1	51.3	3.3	40.0	98.8	4.5	59.9	37.1	2.3	67.6	26.5
	17.0	3.6	8.2	52.0	3.3	40.6	99.2	4.6	61.6	37.5	2.2	69.0	28.6
60	8.5	1.1	2.4	55.0	3.3	43.6	100.9	4.8	58.0	36.6	2.7	67.1	21.7
	12.7	2.2	5.0	58.0	3.3	46.6	102.5	5.1	59.1	37.0	2.5	67.7	23.5
	17.0	3.5	8.0	58.8	3.3	47.4	103.0	5.2	61.3	37.4	2.4	69.3	26.0
70	8.5	1.0	2.4	61.4	3.4	49.9	104.5	5.3	56.6	36.2	3.0	66.7	19.1
	12.7	2.1	4.8	65.3	3.4	53.9	106.7	5.7	57.8	36.6	2.8	67.4	20.7
	17.0	3.3	7.7	66.2	3.4	54.7	107.1	5.8	60.1	37.1	2.6	69.0	22.9
80	8.5	1.0	2.3	68.2	3.4	56.6	108.3	5.9	54.7	35.5	3.3	65.9	16.6
	12.7	2.0	4.7	73.3	3.4	61.8	111.1	6.4	56.0	36.0	3.1	66.6	18.0
	17.0	3.2	7.5	74.2	3.4	62.7	111.7	6.4	58.1	36.4	2.9	68.1	19.8
90	8.5	1.0	2.2	75.5	3.4	63.8	112.4	6.4	52.2	34.6	3.7	64.8	14.2
	12.7	1.9	4.5	81.9	3.4	70.3	115.9	7.1	53.6	35.0	3.5	65.4	15.5
	17.0	3.1	7.2	82.9	3.4	71.2	116.5	7.1	55.5	35.4	3.3	66.8	16.7
100	8.5	0.9	2.1	Operation Not Recommended					49.3	33.3	4.1	63.4	11.9
	12.7	1.9	4.3						50.8	33.7	3.9	64.0	13.1
	17.0	3.0	7.0						52.3	34.1	3.8	65.1	13.9
110	8.5	0.9	2.1	Operation Not Recommended					45.9	31.7	4.7	61.8	9.8
	12.7	1.8	4.2						47.4	32.1	4.4	62.4	10.8
	17.0	2.9	6.7						48.9	32.5	4.2	63.4	11.5

Interpolation is permissible; extrapolation is not.

Operation below 40°F EWT is based upon a 15% antifreeze solution.

All performance is based upon the lower voltage of dual voltage rated units.

Table does not reflect fan or pump power corrections for ARI/ISO conditions.

See performance correction tables for operating conditions other than those listed above.